

NOTE: 1  
 DESIGN CODE:  
 N/A

NOTE: 2  
 TECHNICAL CLASSIFICATION:  
 Article Type: 003-Valve Stabs  
 Main Group: 3.00. Misc-Valvestab  
 Intermediate Group: 3.40.09. Spares  
 Sub Group: 3.40.94.1. Stab

NOTE: 3  
 INTERFACE INFORMATION:  
 Pressure Rating Bar: N/A  
 Material: UNSC63200 (OM7)  
 Weight: 0 kg  
 Volume: 0 dm<sup>3</sup>  
 Surface Area: 19 cm<sup>2</sup>  
 Hydraulic: N/A  
 Mechanical: N/A  
 Electrical: N/A  
 Com. & Protocol: N/A

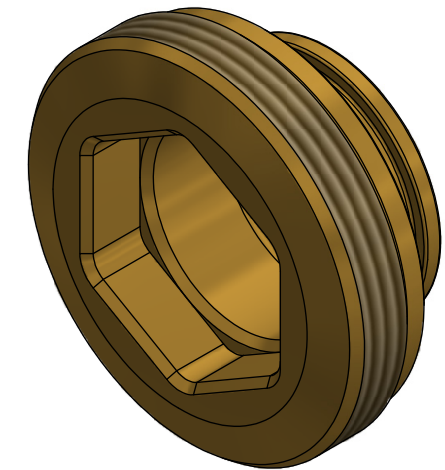
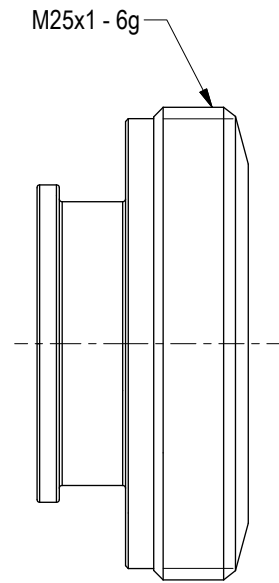
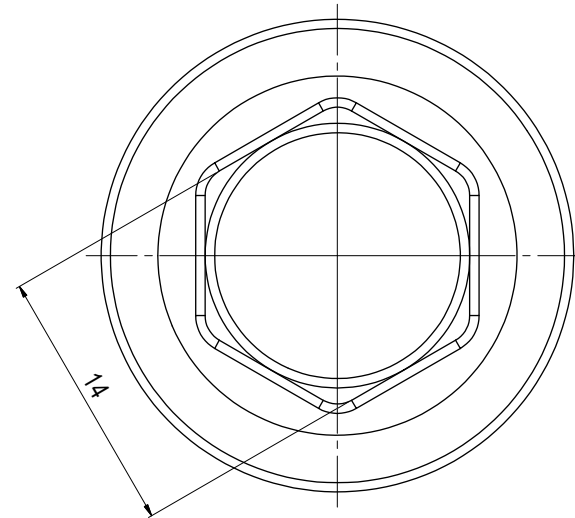
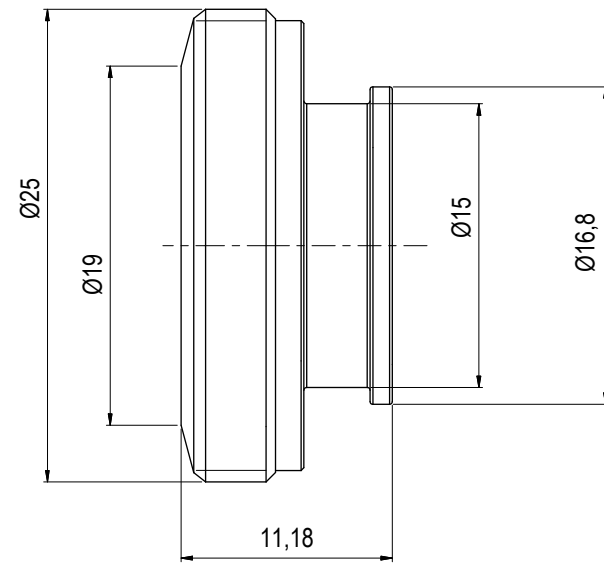

Rev.	Date	Reason for issue	Revision change	Made	Chk'd	Appr.
04	10.6.2024	7-IFC (Issued for Construction)	added tolerances and notes	WTJ	HNJ	WTJ
03	5.10.2011	7-IFC (Issued for Construction)		LGH	EKJ	LGH

**BLUE LOGIC**

This Drawing is the Property of Blue Logic AS © and must Not be Loaned, Reproduced or Transferred to others without written Permission

Unless Noted Otherwise:	Dwg. Scale: NTS
Dim. Tol: NS-ISO 2768-1/A	Dwg. Proj:
Roughness: RaN/A	Dwg. Format: A3
Fillet Rad: Corner Rmax: N/A	Break Edges: (R. Alt. 45°) R= 0,1-0,5

Drawing title: Cartridge for Ø60 VStab	Drawing number: BA1067	Rev: 04
--	------------------------	---------